



DATE: 14 December 2020

I.T.L. (PRODUCT TESTING) LTD.

**Test Report According to
EN 300 328 V2.2.2: (2019)**

for

Pointer Telocation

Equipment under test:

Asset Tracking Device

Cellotrack Power LTE EU

Tested by:

M. Zohar

Approved by:

D. Shidlowsky

This report must not be reproduced, except in full, without the written permission of I.T.L. (Product Testing) Ltd. This report relates only to items tested.



TABLE OF CONTENTS

1.	GENERAL INFORMATION	4
1.1	Administrative Information	4
1.2	Abbreviations and Symbols	5
1.3	List of Accreditations	6
2.	APPLICABLE STANDARD	7
3.	TEST SITE DESCRIPTION	8
3.1	Location:	8
3.2	Shielded Room:	8
3.3	Open Site:	8
3.4	Ground Plane:	8
3.5	Antenna Mast:	8
3.6	Turntable:	8
3.7	EMI Receiver:	9
3.8	E.U.T. Support:	9
3.9	Test Equipment:	9
4.	SUMMARY OF TEST RESULTS	10
5.	EQUIPMENT UNDER TEST (E.U.T.) DESCRIPTION	12
6.	LIST OF TEST EQUIPMENT	13
6.1	Radio Tests	13
7.	E.U.T. MODE OF OPERATION	14
8.	RF OUTPUT POWER	15
8.1	Test Specification	15
8.2	Test Procedure	15
8.3	Test Limit	15
8.4	Test Results	15
9.	POWER SPECTRAL DENSITY	17
9.1	Test Specification	17
9.2	Test Procedure	17
9.3	Test Limit	17
9.4	Test Results	17
10.	OCCUPIED CHANNEL BANDWIDTH	21
10.1	Test Specification	21
10.2	Test Procedure	21
10.3	Test Limit	21
10.4	Test Results	21
11.	TRANSMITTER UNWANTED EMISSION IN THE OOB DOMAIN	23
11.1	Test Specification	23
11.2	Test Procedure	23
11.3	Test Limit	23
11.4	Test Results	23
12.	TRANSMITTER UNWANTED EMISSIONS IN THE SPURIOUS DOMAIN	25
12.1	Test Specification	25
12.2	Test Procedure	25
12.3	Test Limit	26
12.4	Tests Results	26
13.	RECEIVER SPURIOUS EMISSIONS	28
13.1	Test Specification	28
13.2	Test Procedure	28
13.3	Test Limit	29
13.4	Test Results	29



14.	RECEIVER BLOCKING	30
14.1	Test Specification.....	30
14.2	Test Procedure.....	30
14.3	Test Limit.....	31
14.4	Test Results	31
15.	INFORMATION AS REQUIRED BY CLAUSE 5.4.1 ACCORDING TO ANNEX E	33
16.	SET UP PHOTOGRAPHS	37
18.	APPENDIX A - CORRECTION FACTORS	40
18.1	Correction factors for RF OATS Cable 35m	40
18.2	Correction Factors for RF Cable for Anechoic Chamber	41
18.3	Correction Factors for Active Loop Antenna	42
18.4	Correction Factors for Biconical Antenna	43
18.5	Correction Factors for Log Periodic Antenna.....	44
18.6	Correction Factors for Double – Ridged Waveguide Horn ANTENNA 3 meter range;	45
19.	APPENDIX B - MEASUREMENT UNCERTAINTY	46



1. General Information

1.1 Administrative Information

Manufacturer:	Pointer Telocation
Manufacturer's Address:	14 Hamelacha, PO Box 11473 Roash Haain, Israel Tel: +972 73 2622320
Manufacturer's Representative:	Igor Rogov
Equipment Under Test (E.U.T):	Asset Tracking Device
Equipment Model No.:	Cellotrack Power LTE EU
Equipment Serial No.:	Not designated
Date of Receipt of E.U.T:	October 25, 2020
Start of Test:	October 25, 2020
End of Test:	November 08, 2020
Test Laboratory Location:	I.T.L (Product Testing) Ltd. 1 Batsheva St., Lod ISRAEL 7120101
Test Specifications:	300 328 V2.2.2: (2019)



1.2 Abbreviations and Symbols

The following abbreviations and symbols are applicable to this test report:

A/m	ampere per meter
AC	alternating current
AM	amplitude modulation
ARA	Antenna Research Associates
Aux	auxiliary
Avg	average
CBW	channel bandwidth
CDN	coupling-decoupling network
cm	centimeter
dB	decibel
dBm	decibel referred to one milliwatt
db μ V	decibel referred to one microvolt
db μ V/m	decibel referred to one microvolt per meter
DC	direct current
EFT/B	electrical fast transient/burst
EMC	electromagnetic compatibility
ESD	electrostatic discharge
E.U.T.	equipment under test
GHz	gigahertz
HP	Hewlett Packard
Hz	Hertz
kHz	kilohertz
kV	kilovolt
LED	light emitting diode
LISN	line impedance stabilization network
m	meter
mHn	millihenry
MHz	megahertz
msec	millisecond
N/A	not applicable
per	period
QP	quasi-peak
PC	personal computer
RF	radio frequency
RE	radiated emission
sec	second
V	volt
V/m	volt per meter
VRMS	volts root mean square



1.3 List of Accreditations

The EMC laboratory of I.T.L. is accredited by the following bodies:

1. The American Association for Laboratory Accreditation (A2LA) (U.S.A.), Certificate No. 1152.01.
2. The Federal Communications Commission (FCC) (U.S.A.), FCC Designation Number IL1005.
3. The Israel Ministry of the Environment (Israel), Registration No. 1104/01.
4. Innovation, Science and Economic Development Canada (ISED) CAB identifier: IL1002.

I.T.L. Product Testing Ltd. is accredited by the American Association for Laboratory Accreditation (A2LA) and the results shown in this test report have been determined in accordance with I.T.L.'s terms of accreditation unless stated otherwise in the report.



2. Applicable Standard

2.1 **EN 300 328**
V2.2.2 (2019)

Wideband transmission systems; Data transmission equipment operating in the 2,4 GHz band; Harmonised Standard for access to radio spectrum



3. Test Site Description

3.1 Location:

The Electromagnetic Compatibility Test Facility of I.T.L. (Product testing) Ltd. Is located at
Telrad Industrial Park, Lod, 7120101 Israel.
Telephone: +972-8-9153100
Fax: +972-8-9153101

3.2 Shielded Room:

A Modular Shielded Room, Type 20 SpaceSaver, manufactured by ETS, consisting of a Main Room and a Control Room.

The dimensions of the Main Room are: length: 7.0 m, width: 3.0 m, height: 3.0 m.

The shielding performance is:

magnetic field: 60 dB at 10 kHz rising linearly to 100 dB at 100 kHz,

electric field: better than 110 dB between 50 MHz and 1 GHz,

plane wave: 110 dB between 50 MHz and 1 GHz.

All the power lines entering the shielded room are filtered.

3.3 Open Site:

The OATS is located on a one floor-building roof. The OATS consists of 3 meter and 10 meter ranges, using a 21.5m X 8.5m solid metal ground plane, a remote controlled turntable and an antenna mast.

3.4 Ground Plane:

The ground plane is made from steel plates, which are welded continuously together. The Ground plane is lies and welded on welded steel construction with vias to allow for water drainage. All the power, control, and signal lines to the turntable and the 3 m and 10m antenna mast outlets are routed in shielded conduits under the plane to the control building.

3.5 Antenna Mast:

ETS model 2070-2. The antenna position and polarization are remote controlled via Fiber Optical Link using ETS/EMCO Dual Controller Type 2090. The antenna position is adjustable between 1-4 meters. Pressurized air is used to power changing the polarity of the antenna.

3.6 Turntable:

ETS model 2087 series. The position of the turntable is remote-controlled via Fiber Optic Link, using ETS/EMCO Dual Controller Type 2090. The turntable is mounted in a pit and its surface is flush with the Open Site Ground Plane. Brushes near the periphery of the turntable ensure good conductive connection to the ground plane. The Turntable maximum load is 1250 Kg.



3.7 EMI Receiver:

Type ESCI7, manufactured by Rohde & Schwarz, being in full compliance with CISPR 16-1-1 requirements.

3.8 E.U.T. Support:

Table mounted E.U.T.s are supported during testing on 150 cm high all plastic table.

3.9 Test Equipment:

See details in Section 6.

4. Summary of Test Results

Test	Results
<p>RF Output Power EN 300 328 V2.2.2 (2019) Sections 4.3.2.2, 5.4.2</p>	<p>The E.U.T met the performance requirements of the specification.</p>
<p>Power Spectral Density EN 300 328 V2.2.2 (2019) Sections 4.3.2.3, 5.4.3</p>	<p>The E.U.T met the performance requirements of the specification.</p>
<p>Duty Cycle, Tx-Sequence, Tx-Gap EN 300 328 V2.2.2 (2019) Sections 4.3.2.4; 5.4.2</p>	<p>N/A</p>
<p>Medium Utilization Factor EN 300 328 V2.2.2 (2019) Sections 4.3.2.5, 5.4.2</p>	<p>N/A</p>
<p>Adaptivity EN 300 328 V2.2.2 (2019) Sections 4.3.2.6, 5.4.6</p>	<p>N/A</p>
<p>Occupied Channel Bandwidth EN 300 328 V2.2.2 (2019) Sections 4.3.2.7, 5.4.7</p>	<p>The E.U.T met the performance requirements of the specification.</p>
<p>Transmitter Unwanted Emission in the Out-of-Band Domain EN 300 328 V2.2.2 (2019) Sections 4.3.2.8, 5.4.8</p>	<p>The E.U.T met the performance requirements of the specification.</p>



Summary of Test Results (cont'd.)

Test	Results
Transmitter Unwanted Emission in Spurious Domain EN 300 328 V2.2.2 (2019) Section 4.3.2.9, Section 5.4.9	The E.U.T met the performance requirements of the specification.
Receiver Spurious Emission EN 300 328 V2.2.2 (2019) Section 4.3.2.10, Section 5.4.10	The E.U.T met the performance requirements of the specification.
Receiver Blocking EN 300 328 V2.2.2 (2019) Section 4.3.2.11, Section 5.4.11	The E.U.T met the performance requirements of the specification.
Geo-Location Capability EN 300 328 V2.2.2 (2019) Section 4.3.2.12	N/A

5. Equipment Under Test (E.U.T.) Description

The CelloTrack product line is designed for advanced asset tracking and remote monitoring, featuring enhanced functionality with full fleet management capabilities, robustness and ease of installation, suitable for a wide variety of asset management applications.

The CelloTrack product line is available in two variants – a standalone version and a power version, which includes extended battery life and the ability to connect external sensors via two configurable GPIOs. Models are suitable for 2G, 3G and 4G (LTE) cellular communication technologies.

Working voltage	12VDC Rechargeable battery operated via AC/DC adapter
Mode of operation	BLE Transceiver
Modulations	GFSK
Assigned Frequency Range	2400.0-2483.5MHz
Operating Frequency Range	2402.0-2480.0MHz
Transmit power(conducted)	~5.0dBm
Antenna Gain	+1.9 dBi chip antenna
Modulation BW	2MHz
Bit rate (Mbit/s)	1, 2, 3
Temperature Range for extreme conditions	-30.0°C - +70.0°C
Receiver category	2
Adaptive / not adaptive	Adaptive (LBT based Detect and Avoid mechanism)
*See additional information according to Annex E in section 16.	

6. List of Test Equipment

6.1 Radio Tests

The equipment listed below were used for testing according to EN 300 328 V2.2.2 (2019), Sections 5.4.2-5.4.11

Test equipment calibration is in accordance with ITL Q.A. Procedure PM 110 "Calibration Control Procedure", which complies with ISO/IEC Guide 17025.

Instrument	Manufacturer	Model	Serial No.
Spectrum Analyzer	HP	8593EM	3536A00120ADI
EMI Receiver	HP	8542E	3906A00276
RF Filter Section	HP	85420E	3705A00248
Horn Antenna	ETS	3115	6142
Biconical Antenna	EMCO	3110B	9912-3337
Log Periodic Antenna	EMCO	3146	9505-4081
Semi Anechoic Civil Chamber	ETS	S81	SL 11643
Environmental Chamber	Thermotron	SM-32C	251030
Radi Power USB RF Power Sensor	DARE	RPR3006W	14I00048SNO085
MicroWave System Amplifier	HP	83006A	3104A00589
Low noise amplifier 1GHz-18GHz	Miteq	AFSX4-02001800-50-8P	-
Signal Generator	WILTRON	6747B	278007
Spectrum Analyzer	R&S	FSL6	MY50000243
Directional Coupler	KRYTAR	101020010	88873
Power Divider	NARDA	25888	284
70 dB Step Attenuator	HP	8495D	3308A01554
AWG Signal Generator	OSR	-	-
Antenna Mast	ETS	2070-2	9608-1497
Turntable	ETS	2087	-
Mast & Table Controller	ETS/EMCO	2090	9608-1456

7. E.U.T. Mode of Operation

1. The E.U.T contains an IEEE 802.15.1 standard (BLE) transceiver.
2. The unit was evaluated while transmitting at the low channel (2402MHz), the mid channel (2440MHz) and the high channel (2480MHz).
3. The evaluation was performed with the E.U.T connected to a typical 12VDC battery.
4. Conducted emission tests were performed with the E.U.T. antenna terminal connected by a RF cable to the Spectrum Analyzer through a 30dB external attenuator.
5. Final radiated emission test for spurious emission was performed after exploratory emission testing that was performed in 3 orthogonal polarities to determine the “worst case” radiation and find at Y axis.

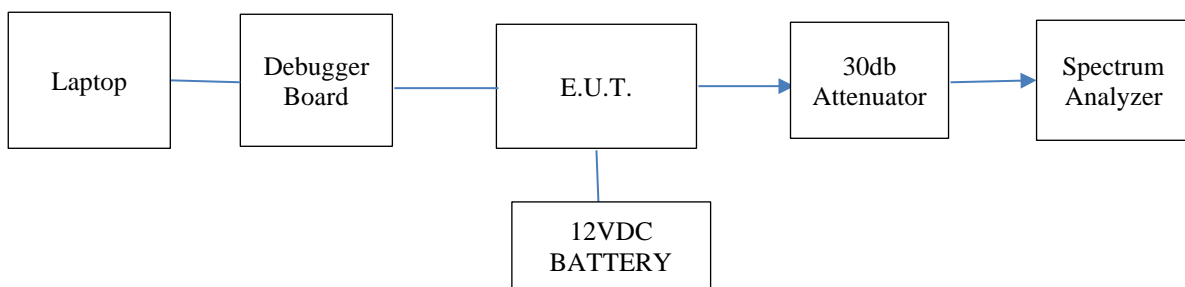

Figure 1. Configuration of Tested System - Conducted

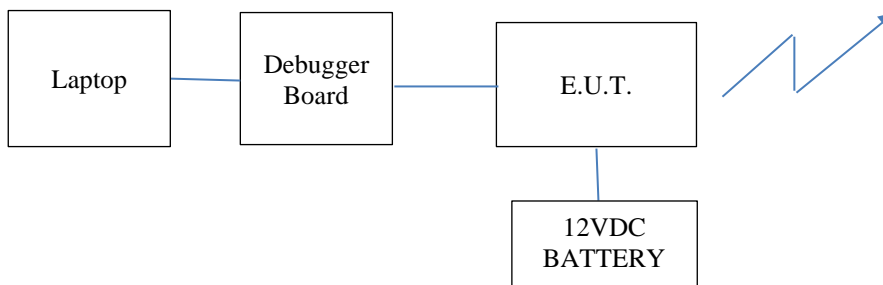

Figure 2. Configuration of Tested System - Radiated

8. RF Output Power

8.1 Test Specification

EN 300 328 V2.2.2 (2019), Sections 4.3.2.2, 5.4.2

8.2 Test Procedure

(Temperature (23°C)/ Humidity (60%RH))

The E.U.T operation mode and test setup are as described in Section 7.

Conducted emission was performed when the E.U.T. was placed in the thermal chamber for extreme environmental conditions.

The E.U.T was evaluated with power sensor with an 1MS/s fitted RMS detector.

The results were recorded.

8.3 Test Limit

For adaptive equipment using wide band modulations other than FHSS, the maximum RF output power shall be 20 dBm. The maximum RF output power for non-adaptive equipment shall be declared by the supplier and shall not exceed 20 dBm. For non-adaptive equipment using wide band modulations other than FHSS, the maximum RF output power shall be equal to or less than the value declared by the manufacturer.

8.4 Test Results

The E.U.T met the requirements of the EN 300 328 V2.2.2 (2019), Sections 4.3.2.2, 5.4.2.

Additional information of the results is given in *Figure 3*.

Equivalent Isotropic Radiated Power

Protocol Type	Channel	Temperature	RMS Power Reading	Antenna Gain	EIRP	Limit	Margin
		(°C)	(dBm)	(dBi)	(dBm)	(dBm)	(dB)
BLE	Low	+25.0	5.0	+1.9	6.9	20.0	-13.1
		+70.0	4.6	+1.9	6.5	20.0	-13.5
		-30.0	6.6	+1.9	8.5	20.0	-11.5
	Mid	+25.0	5.0	+1.9	6.9	20.0	-13.1
		+70.0	4.6	+1.9	6.5	20.0	-13.5
		-30.0	6.9	+1.9	8.8	20.0	-11.2
	High	+25.0	4.7	+1.9	6.6	20.0	-13.4
		+70.0	4.5	+1.9	6.4	20.0	-13.6
		-30.0	6.7	+1.9	8.6	20.0	-11.4

Figure 3. EIRP Test Results

9. Power Spectral Density

9.1 Test Specification

EN 300 328 V2.2.2 (2019), Sections 4.3.2.3; 5.4.3

9.2 Test Procedure

(Temperature (20°C)/ Humidity (59%RH))

The E.U.T operation mode and test set-up are as described in section 7 of this report.

Conducted emission was performed with the E.U.T was connected to the spectrum via suitable attenuator.

The measurement was performed at normal test conditions and in the lowest, middle and highest operational frequency range.

Spectrum analyzer setting:

Step 1: RBW=1MHz , VBW=3MHz , detector: peak ,trace: “max hold”,
span: $2 \times$ Nominal Bandwidth

When the trace is complete the highest peak value of the power envelope founded

Step 2: RBW=1MHz , VBW \geq 3MHz , detector: RMS ,trace: “max hold”,
span: 3MHz, sweep time: 1 minute

this peak value of the trace is highest mean power (power spectral density) D in a 1 MHz band.

The total PSD was calculated according the next formula:

$PSD = D + G + Y + 10 \times \log (1 / DC)$ (dBm / MHz)

When:

G- E.U.T antenna gain

Y- beamforming gain(if applicable)

DC- (observed Duty Cycle in section 9)

9.3 Test Limit

For equipment using wide band modulations other than FHSS, the maximum Power Spectral Density is limited to 10 dBm per MHz.

9.4 Test Results

The E.U.T met the requirements of the EN 300 328 V2.2.2 (2019), Sections 4.3.2.3; 5.4.3 specifications.

Additional information of the results is given in *Figure 4* to *Figure 7*.



Power Spectral Density

E.U.T Description Asset Tracking Device
Type Cellotrack Power LTE EU
Serial Number: Not designated

Protocol Type	Channel	PSD	G	D.C Factor	TOTAL PSD	Limit	Margin
	(low/mid/high)	(dBm/MHz)	(dBi)	(dB)	(dBm/MHz)	(dBm/MHz)	(dB)
BLE	Low	5.2	1.9	-	7.1	10.0	-2.9
	Mid	5.3	1.9	-	7.2	10.0	-2.8
	High	4.9	1.9	-	6.8	10.0	-3.2

**note: duty cycle factor negligible because measurements done with peak detector and "max hold"*

Figure 4. Power Spectral Density Test Results

Power Spectral Density

E.U.T Description Asset Tracking Device
 Type Cellotrack Power LTE EU
 Serial Number: Not designated

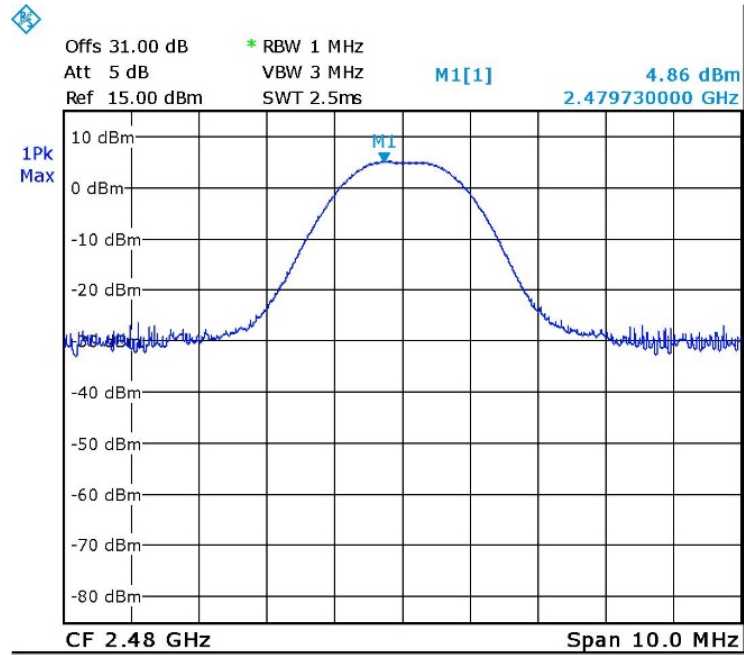

Figure 7. High Channel, BLE

10. Occupied Channel Bandwidth

10.1 Test Specification

EN 300 328 V2.2.2 (2019), Sections 4.3.2.7, 5.4.7

10.2 Test Procedure

(Temperature (22°C)/ Humidity (56%RH))

The E.U.T operation mode and test setup are as described in Section 7 of this report.

Conducted emission was performed when the E.U.T was connected to the spectrum via suitable attenuator.

The lowest and the highest operating channels of the E.U.T. were selected.

The RBW was set to ~ 1 % of the span without going below 1 %.

Detector used: RMS, trace mode: max hold, sweep time: 1second.

The automatic channel bandwidth test was activated at the SA (99% BW).

These measurements were performed at normal test conditions.

10.3 Test Limit

The Occupied Channel Bandwidth shall fall completely within the band given in Table 1 in the standard.

In addition, for non-adaptive equipment using wide band modulations other than FHSS and with e.i.r.p greater than 10 dBm, the occupied channel bandwidth shall be less than 20 MHz.

10.4 Test Results

The E.U.T met the requirements of the EN 300 328 V2.2.2 (2019), Sections 4.3.2.7, 5.4.7.

Additional information of the results is given in *Figure 8* to *Figure 9*.

Occupied Channel Bandwidth

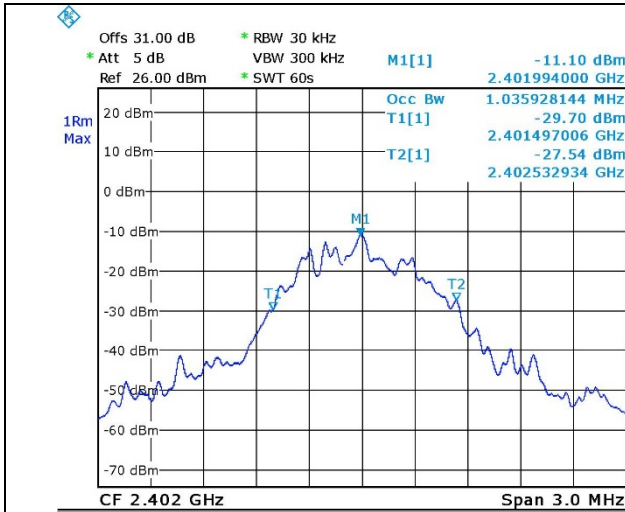

Figure 8. Low Frequency, BLE Mode

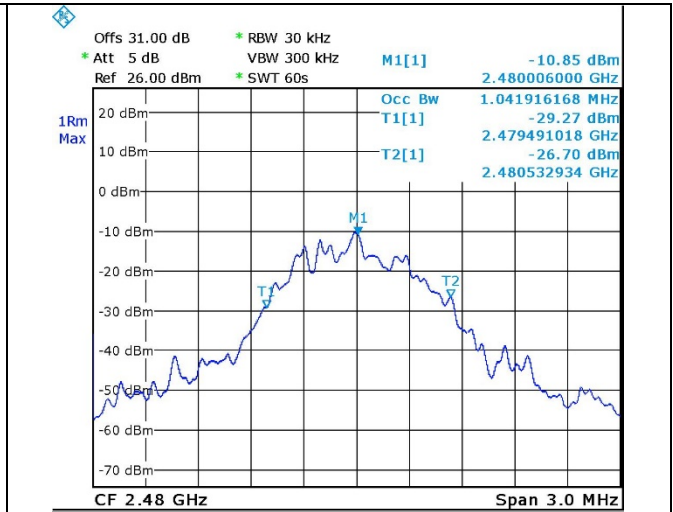

Figure 9. High Frequency, BLE Mode

11. Transmitter Unwanted Emission in the OOB Domain

11.1 Test Specification

EN 300 328 V2.2.2 (2019), Sections 4.3.2.8, 5.4.8

11.2 Test Procedure

(Temperature (23°C)/ Humidity (60%RH))

The E.U.T operation mode and test setup are as described in Section 7 of this report. Conducted emission was performed when the E.U.T was connected to the spectrum via suitable attenuator.

The lowest operating frequency and the highest operating frequency of the E.U.T. were selected.

Spectrum analyzer set: Detector: RMS, Trace: max hold, sweep points: 5000.

Sweep time: > 120 % of the duration of the longest burst detected.

These measurements were performed at normal test conditions.

11.3 Test Limit

The unwanted emissions in the OOB shall not exceed the values provided by the mask:

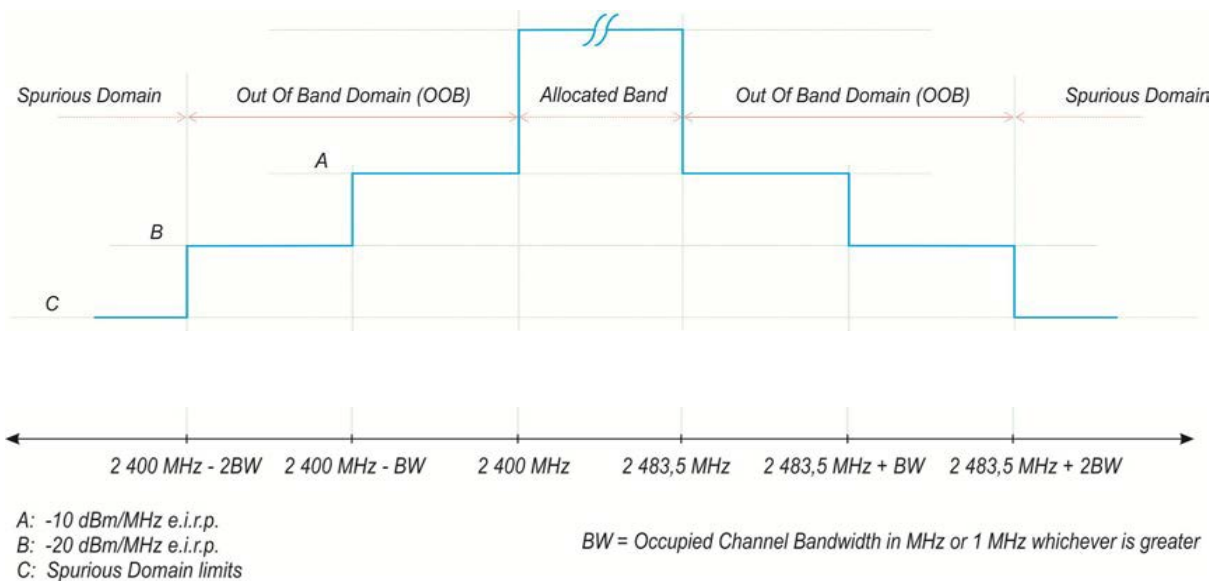

11.4 Test Results

The E.U.T met the requirements of the EN 300 328 V2.2.2 (2019), Sections 4.3.2.8, 5.4.8.

Additional information of the results is given in *Figure 10* to *Figure 11*.

Emission in the OOB Domain

E.U.T Description	Asset Tracking Device
Type	Cellotrack Power LTE EU
Serial Number:	Not designated

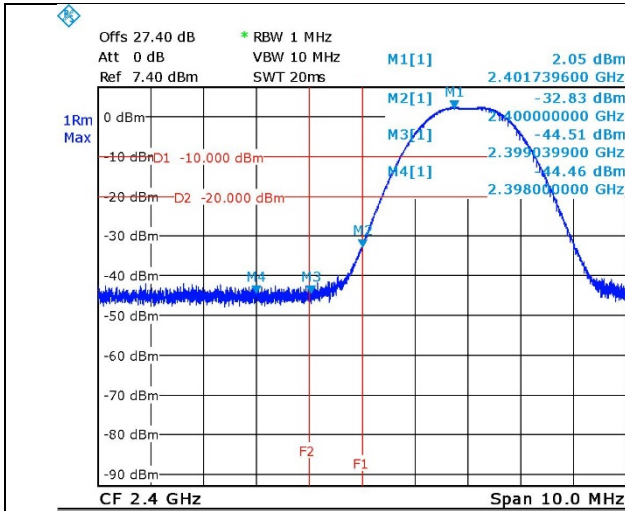

Figure 10. Low Frequency, BLE Mode

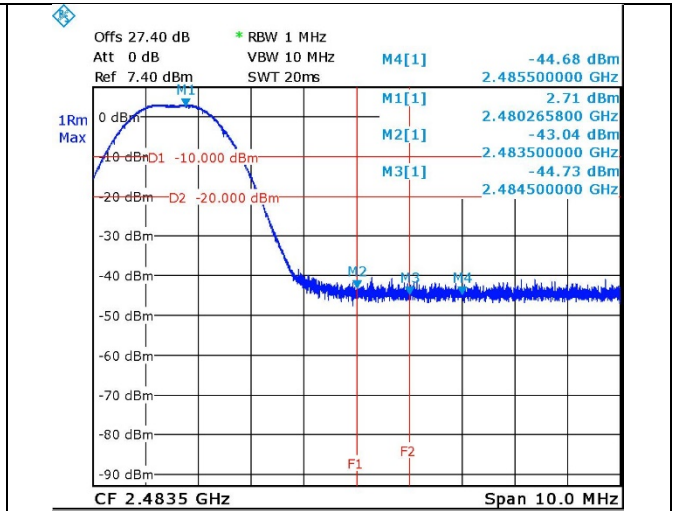

Figure 11. High Frequency, BLE Mode

12. Transmitter Unwanted Emissions in the Spurious Domain

12.1 Test Specification

EN 300 328 V2.2.2 (2019), Sections 4.3.2.9, 5.4.9

12.2 Test Procedure

(Temperature (23°C)/ Humidity (60%RH))

The test was performed in the frequency band of 30MHz –12.75GHz.

For 30.0MHz-1000.0MHz range:

A preliminary measurement to characterize the E.U.T was performed inside the shielded room at a distance of 3 meters, using peak detection mode and broadband antennas. The preliminary measurements produced a list of the highest emissions. The E.U.T was then transferred to the open site, and placed on a remote-controlled turntable. The E.U.T was placed on a non-metallic table, 1.5 meters above the ground. The distance between the E.U.T and the testing antenna was 3 meters.

The readings were maximized by adjusting the antenna height between 1-4 meters, the turntable azimuth between 0-360°, and the antenna polarization.

The frequency range 30 MHz-1000 MHz was scanned.

For 1000.0MHz-12,750.0MHz range:

The E.U.T was placed in the chamber and placed on a remote-controlled turntable.

The E.U.T was placed on a non-metallic table, 1.5 meters above the ground. The distance between the E.U.T and the testing antenna was 3 meters.

The readings were maximized by adjusting the turntable azimuth between 0-360° and the antenna polarization.

The frequency range 1000 MHz-12750 MHz was scanned.

For all the tests a RMS detector was used.

The E.U.T. was replaced by a substitution antenna. The substitution antenna was driven by a signal generator operating in C.W. Mode. The height of the test antenna was adjusted for maximum level.

The input signal of the substitution antenna was adjusted to the level that produced a receiver reading equal to the level noted while the spurious emissions of the E.U.T. were measured.

The above tests were performed in both horizontal and vertical polarizations.

The transmitter was set to the lowest operating frequency and to the highest operating frequency.

The spurious emission was calculated as follows:

Signal Generator Level (dBm) – Cable Loss (dB) + Substitution Antenna Gain (dBi/dBd).

The E.U.T was evaluated in Tx mode.

12.3 Test Limit

The transmitter unwanted emissions in the spurious domain shall not exceed the values given in the next table. In case of equipment with antenna connectors, these limits apply to emissions at the antenna port (conducted). For emissions radiated by the cabinet or emissions radiated by integral antenna equipment (without antenna connectors), these limits are e.r.p. for emissions up to 1 GHz and as e.i.r.p. for emissions above 1 GHz.

Frequency range	Maximum power	Measurement bandwidth
30 MHz to 47 MHz	-36 dBm	100 kHz
47 MHz to 74 MHz	-54 dBm	100 kHz
74 MHz to 87,5 MHz	-36 dBm	100 kHz
87,5 MHz to 118 MHz	-54 dBm	100 kHz
118 MHz to 174 MHz	-36 dBm	100 kHz
174 MHz to 230 MHz	-54 dBm	100 kHz
230 MHz to 470 MHz	-36 dBm	100 kHz
470 MHz to 862 MHz	-54 dBm	100 kHz
862 MHz to 1 GHz	-36 dBm	100 kHz
1 GHz to 12,75 GHz	-30 dBm	1 MHz

12.4 Tests Results

The E.U.T met the specification EN 300 328 V2.2.2 (2019), Sections 4.3.2.9, 5.4.9. Additional information of the results is given in *Figure 12*.

Protocol Type	Operation Freq.	Freq.	Field Strength	Pol.	Generator Output Power	Cable Loss	Antenna Gain	EIRP	Limit	Margin
	(MHz)	(MHz)	(dB μ V/m)	(V/H)	(dBm)	(dB)	(dBi)	(dBm)	(dBm)	(dB)
BLE	2402.0	4804.0	43.4(N.L)	V	-62.0	1.0	10.5	-52.5	-30.0	-22.5
		4804.0	44.0(N.L)	H	-61.5	1.0	10.5	-52.0	-30.0	-22.0
	2480.0	4960.0	43.7(N.L)	V	-62.0	1.0	10.5	-52.5	-30.0	-22.5
		4960.0	43.6(N.L)	H	-61.5	1.0	10.5	-52.0	-30.0	-22.0

Figure 12. Radiated Spurious Emissions

Note: Margin refers to the test results obtained minus specified requirement; thus a positive number indicates failure, and a negative result indicates that the product passes the test.

13. Receiver Spurious Emissions

13.1 Test Specification

EN 300 328 V2.2.2 (2019), Sections 4.3.2.10, 5.4.10

13.2 Test Procedure

(Temperature (20°C)/ Humidity (58%RH))

The test was performed in the frequency band of 30MHz –12.75GHz.

For 30.0MHz-1000.0MHz range:

A preliminary measurement to characterize the E.U.T was performed inside the shielded room at a distance of 3 meters, using peak detection mode and broadband antennas. The preliminary measurements produced a list of the highest emissions. The E.U.T was then transferred to the open site, and placed on a remote-controlled turntable. The E.U.T was placed on a non-metallic table, 1.5 meters above the ground. The distance between the E.U.T and the testing antenna was 3 meters. The readings were maximized by adjusting the antenna height between 1-4 meters, the turntable azimuth between 0-360°, and the antenna polarization. The frequency range 30 MHz-1000 MHz was scanned.

For 1000MHz-12,750MHz range:

The E.U.T was placed in the chamber and placed on a remote-controlled turntable. The E.U.T was placed on a non-metallic table, 1.5 meters above the ground. The distance between the E.U.T and the testing antenna was 3 meters. The readings were maximized by adjusting the turntable azimuth between 0-360° and the antenna polarization. The frequency range 1000 MHz-12750 MHz was scanned.

For all the tests a RMS detector was used.

The E.U.T. was replaced by a substitution antenna. The substitution antenna was driven by a signal generator operating in C.W. Mode. The height of the test antenna was adjusted for maximum level.

The input signal of the substitution antenna was adjusted to the level that produced a receiver reading equal to the level noted while the spurious emissions of the E.U.T. were measured.

The above tests were performed in both horizontal and vertical polarizations.

The transmitter was set to the lowest operating frequency and to the highest operating frequency.

The spurious emission was calculated as follows:

Signal Generator Level (dBm) – Cable Loss (dB) + Substitution Antenna Gain (dBi/dBd).

The E.U.T was evaluated in Rx mode.

13.3 Test Limit

The transmitter unwanted emissions in the spurious domain shall not exceed the values given in the next table. In case of equipment with antenna connectors, these limits apply to emissions at the antenna port (conducted). For emissions radiated by the cabinet or emissions radiated by integral antenna equipment (without antenna connectors), these limits are e.r.p. for emissions up to 1 GHz and as e.i.r.p. for emissions above 1 GHz.

Frequency range	Maximum power	Measurement bandwidth
30 MHz to 1 GHz	-57 dBm	100 kHz
1 GHz to 12,75 GHz	-47 dBm	1 MHz

13.4 Test Results

The E.U.T met the requirements of EN 300 328 V2.2.2 (2019), Sections 4.3.2.10, 5.4.10 specification.

All signals were below the EMI Receiver noise level which is at least 6 dB below the specification limit.

14. Receiver Blocking

14.1 Test Specification

EN 300 328 V2.2.2 (2019), Sections 4.3.2.11, 5.4.11

14.2 Test Procedure

(Temperature (23°C)/ Humidity (60%RH))

The E.U.T operation mode was in receive mode, test setup and levels are as described below.

Alternative performance criteria were declared by the manufacturer as receive packet every 1sec with 100% success

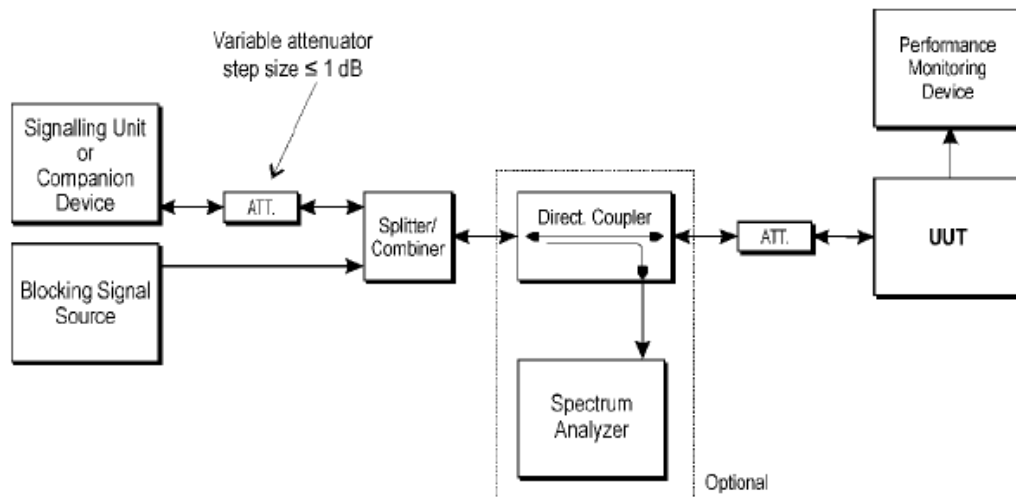

Figure 13. Test Setup

14.3 Test Limit

Table 15: Receiver Blocking parameters receiver Category 2 equipment

Wanted signal mean power from companion device (dBm) (see notes 1 and 3)	Blocking signal frequency (MHz)	Blocking signal power (dBm) (see note 3)	Type of blocking signal
(-139 dBm + 10 × log ₁₀ (OCBW) + 10 dB) or (-74 dBm + 10 dB) whichever is less (see note 2)	2 380 2 504 2 300 2 584	-34	CW
NOTE 1: OCBW is in Hz. NOTE 2: In case of radiated measurements using a companion device and the level of the wanted signal from the companion device cannot be determined, a relative test may be performed using a wanted signal up to P _{min} + 26 dB where P _{min} is the minimum level of wanted signal required to meet the minimum performance criteria as defined in clause 4.3.1.12.3 in the absence of any blocking signal. NOTE 3: The level specified is the level at the UUT receiver input assuming a 0 dBi antenna assembly gain. In case of conducted measurements, this level has to be corrected for the (in-band) antenna assembly gain (G). In case of radiated measurements, this level is equivalent to a power flux density (PFD) in front of the UUT antenna with the UUT being configured/positioned as recorded in clause 5.4.3.2.2.			

14.4 Test Results

The E.U.T met the requirements of the EN 300 328 V2.2.2 (2019), Sections 4.3.2.11, 5.4.11

Additional information of the results is given in *Figure 15* to *Figure 18*.

Receiver Channel	Blocking Signal Frequency	Blocking Signal CW Power	Minimum Performance Criteria
(Low/High)	(MHz)	(dBm)	(Pass/Fail)
Low	2380.0	-16.2	Pass
	2300.0	-16.0	Pass
High	2504.0	-16.3	Pass
	2584.0	-16.8	Pass

Figure 14 – BLE - Receiver Blocking Test Results

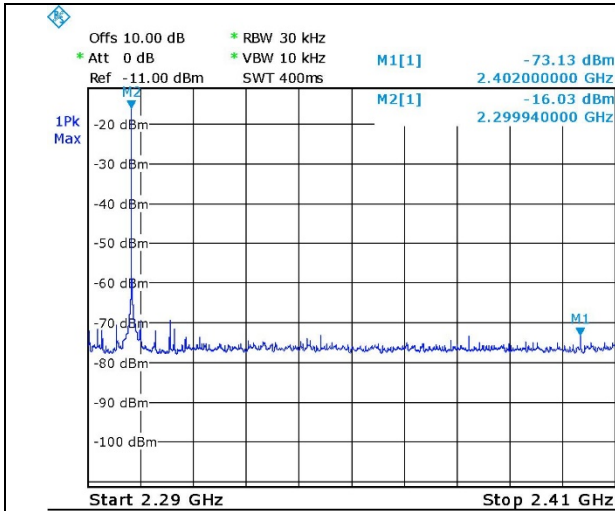

Figure 15. Blocking Signal 2300.0MHz

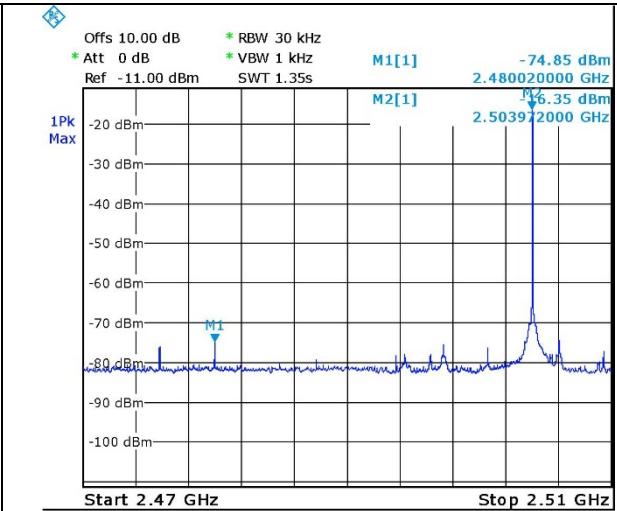

Figure 16. Blocking Signal 2504.0MHz

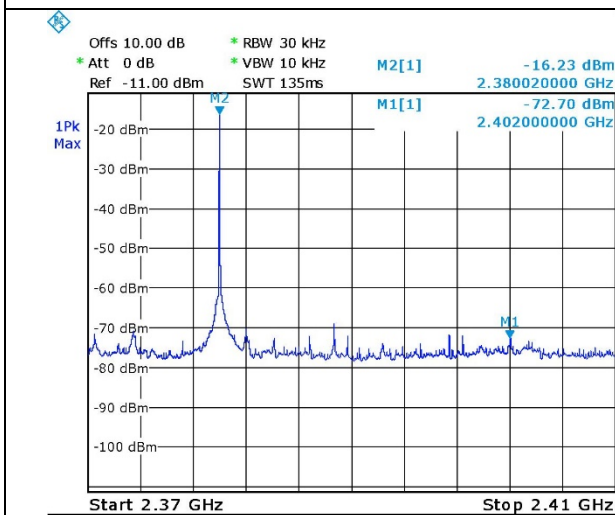

Figure 17. Blocking Signal 2380.0MHz

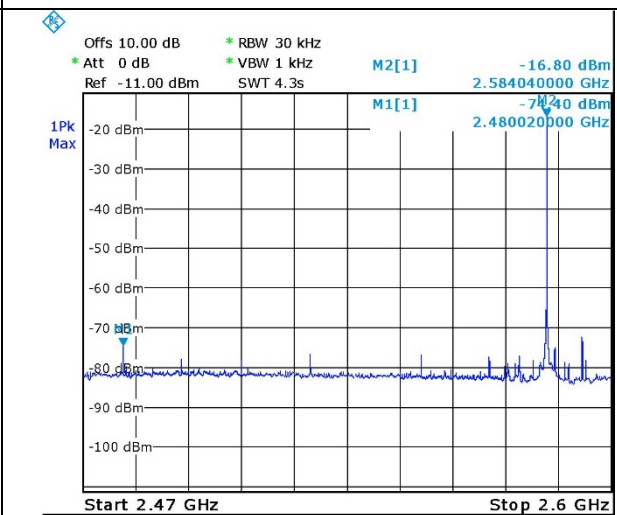

Figure 18. Blocking Signal 2584.0MHz



15. Information as Required by Clause 5.4.1 According to Annex E

E.2 Information as required by EN 300 328 V2.2.2, clause 5.4.1

In accordance with ETSI EN 300 328, clause 5.4.1, the following information is provided by the manufacturer.

a) **The type of wideband data transmission equipment:**

- FHSS
- non-FHSS

b) **Adaptive / non-adaptive equipment:**

- non-adaptive Equipment
- adaptive Equipment without the possibility to switch to a non-adaptive mode
- adaptive Equipment which can also operate in a non-adaptive mode

c) **In case of adaptive equipment:**

The maximum Channel Occupancy Time implemented by the equipment: .40ms

- The equipment has implemented an LBT mechanism
 - In case of non-FHSS equipment:
 - The equipment is Frame Based equipment
 - The equipment is Load Based equipment
 - The equipment can switch dynamically between Frame Based and Load Based equipment
- The CCA time implemented by the equipment: μ s

The equipment has implemented a DAA mechanism

The equipment can operate in more than one adaptive mode



e) In case of non-adaptive Equipment:

The maximum RF Output Power (e.i.r.p.): dBm

The maximum (corresponding) Duty Cycle: %

Equipment with dynamic behaviour, that behaviour is described here. (e.g. the different combinations of duty cycle and corresponding power levels to be declared):

.....
.....
.....

f) The worst case operational mode for each of the following tests:

- RF Output Power:
All modes limited to +10dBm per Spec (need discussion on whether customer implements different power profiles for advertising and connected states for example)
 - Power Spectral Density :
Should be identical in all modes (advertising and/or connected)
- Duty cycle, Tx-Sequence, Tx-gap
N/A: Only applicable to non-adaptive equipment
- Accumulated Transmit time, Frequency Occupation & Hopping Sequence (only for FHSS equipment)
N/A: Only applicable for FHSS systems
- Hopping Frequency Separation (only for FHSS equipment)
N/A: Only applicable for FHSS systems
- Medium Utilization
N/A: Only applicable to non-adaptive equipment
- Adaptivity & Receiver Blocking
N/A: Only applicable to systems transmitting > +10dBm
- Nominal Channel Bandwidth
Should be identical in all modes (advertising and/or connected)
- Transmitter unwanted emissions in the OOB domain
Should be identical in all modes (advertising and/or connected)
- Transmitter unwanted emissions in the spurious domain
Should be identical in all modes (advertising and/or connected)
- Receiver spurious emissions.....
Should be identical in all modes (advertising and/or connected)

g) The different transmit operating modes (tick all that apply):

- Operating mode 1: Single Antenna Equipment
 - Equipment with only one antenna
 - Equipment with two diversity antennas but only one antenna active at any moment in time
 - Smart Antenna Systems with two or more antennas, but operating in a (legacy) mode where only one antenna is used (e.g. IEEE 802.11™ legacy mode in smart antenna systems)



i) Operating Frequency Range(s) of the equipment:

- Operating Frequency Range 1: .2402 MHz to 2480 MHz

j) Nominal Channel Bandwidth(s):

- Nominal Channel Bandwidth 1: 1.2 MHz

k) Type of Equipment (stand-alone, combined, plug-in radio device, etc.):

- Stand-alone
- Combined Equipment
- Plug-in radio device
- Other

l) The normal and the extreme operating conditions that apply to the equipment:

Normal operating conditions (if applicable):

Operating temperature: ...25 ° C
 Other (please specify if applicable):

Extreme operating conditions:

Operating temperature range: Minimum: -30 ° C Maximum +70° C
 Other (please specify if applicable): Minimum: Maximum

- Details provided are for the: stand-alone equipment
 combined equipment
 test jig

m) The intended combination(s) of the radio equipment power settings and one or more antenna assemblies and their corresponding e.i.r.p. levels:

- Antenna Type:
 - Integral Antenna (information to be provided in case of conducted measurements)
 - Antenna Gain: 1.72 dBi
 - If applicable, additional beamforming gain (excluding basic antenna gain): dB
 - Temporary RF connector provided
 - No temporary RF connector provided

n) The nominal voltages of the stand-alone radio equipment or the nominal voltages of the combined equipment or test jig in case of plug-in devices:

Details provided are for the: stand-alone equipment
 combined equipment
 test jig

Supply Voltage AC mains State AC voltage V
 DC State DC voltage 9-32. V

In case of DC, indicate the type of power source

- Internal Power Supply
- External Power Supply or AC/DC adapter
- Battery
- Other:

o) Describe the test modes available which can facilitate testing:

Direct Test Mode is available, but shouldn't be required for this (especially given regulatory certification test is performed at the product level whereas DTM is component (chip) level functionality)

16. Set Up Photographs

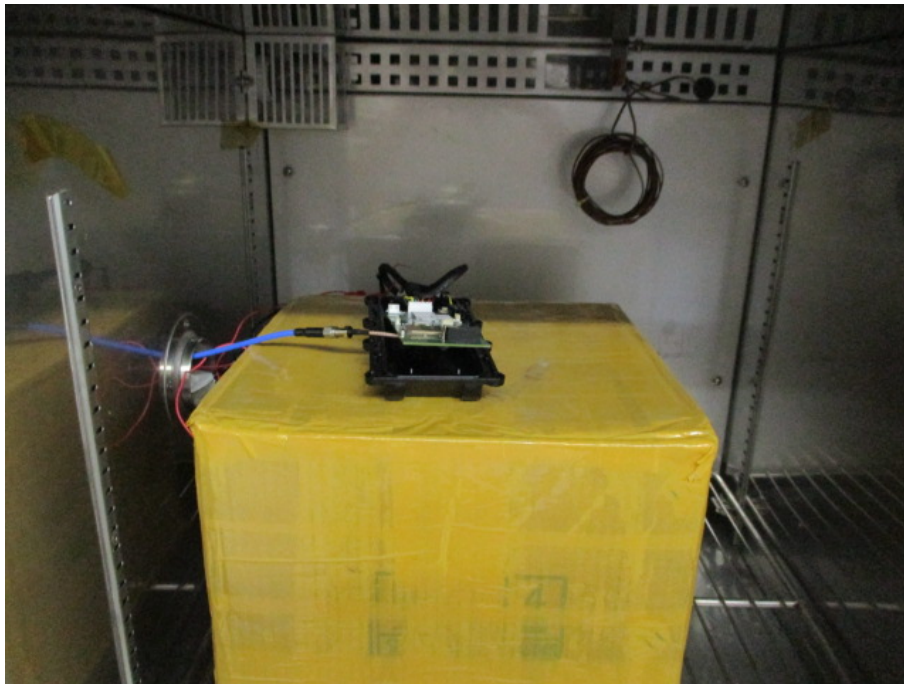

Figure 19. RF Output Power Test

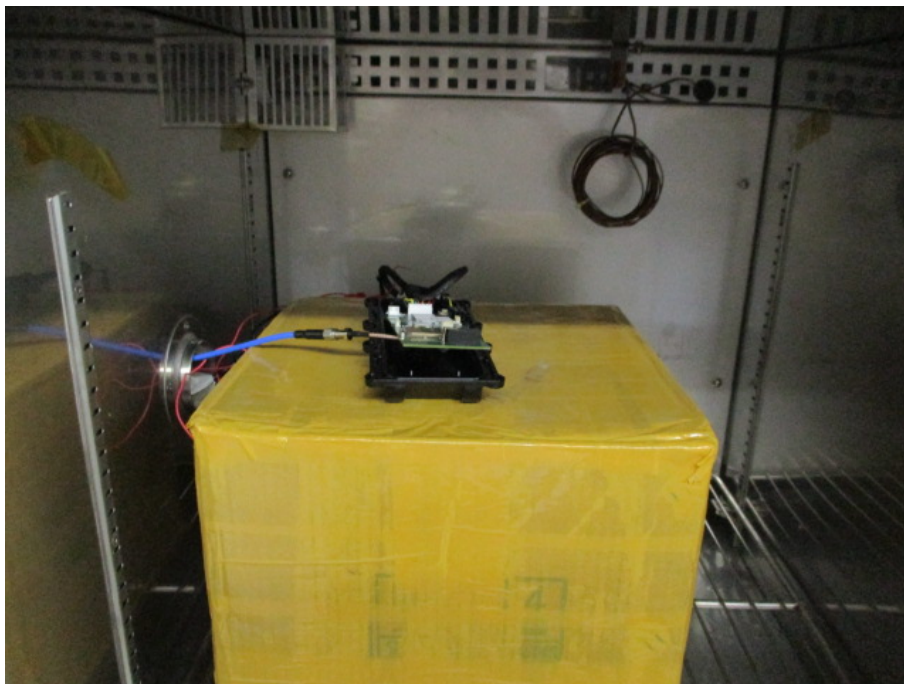

Figure 20 Occupied Channel Bandwidth

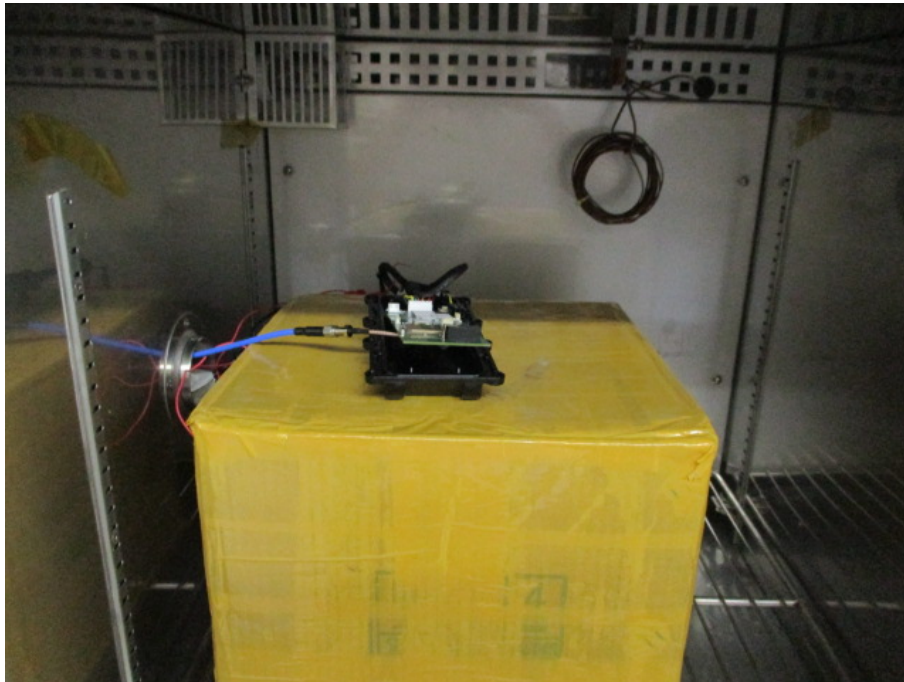

Figure 21 Transmitter Unwanted Emission in the OOB Domain

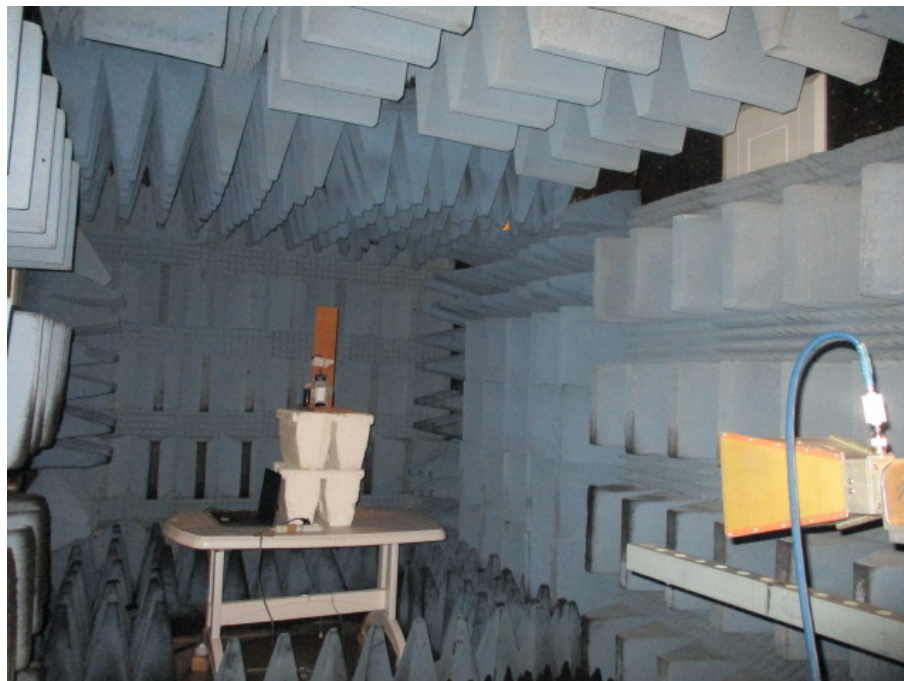

Figure 22 Spurious Emission (Tx/Rx) Test, 1000-12,750MHz



Figure 23 Receiver Blocking Test



18. APPENDIX A - CORRECTION FACTORS

18.1 Correction factors for RF OATS Cable 35m

ITL #1911

Frequency (MHz)	loss (dB)
30.0	1.3
50.0	1.7
100.0	2.6
200.0	3.7
300.0	4.7
400.0	5.5
500.0	6.3
600.0	7.0
700.0	7.6
800.0	8.4
900.0	9.0
1000.0	9.6



**18.2 Correction Factors for RF Cable for Anechoic Chamber
ITL #1840**

FREQ (MHz)	LOSS (dB)
1000.0	1.5
2000.0	2.1
3000.0	2.7
4000.0	3.1
5000.0	3.5
6000.0	4.1
7000.0	4.6
8000.0	4.9
9000.0	5.7
10000.0	5.7
11000.0	6.1
12000.0	6.1
13000.0	6.2
14000.0	6.7
15000.0	7.4
16000.0	7.5
17000.0	7.9
18000.0	8.1
19000.0	8.8
20000.0	9.1

NOTES:

- 1. The cable is manufactured by Commscope*
- 2. The cable type is 0623 WBC-400, serial # G020132 and 10m long*



18.3 Correction Factors for Active Loop Antenna
ITL # 1075

F(MHz)	AF(dB/m)
0.01	18.4
0.02	14.3
0.03	13.3
0.05	11.7
0.1	11.4
0.2	11.2
0.3	11.2
0.5	11.2
0.7	11.2
1	11.4
2	11.5
3	11.5
4	11.4
5	11.3
6	11.1
7	11.1
8	11.1
9	11
10	11
20	10
30	8



18.4 Correction Factors for Biconical Antenna
ITL #1356, EMCO 3110B 9912-3337

Frequency	AF
[MHz]	[dB/m]
30	13.00
35	10.89
40	10.59
45	10.63
50	10.12
60	9.26
70	7.74
80	6.63
90	8.23
100	11.12
120	13.16
140	13.07
160	14.80
180	16.95
200	17.17



18.5 **Correction Factors for Log Periodic Antenna**
ITL # 1349, EMCO 3146 s/n 9505-4081

Frequency	AF
[MHz]	[dB/m]
200	11.58
250	12.04
300	14.76
400	15.55
500	17.85
600	18.66
700	20.87
800	21.15
900	22.32
1000	24.22



**18.6 Correction Factors for Double – Ridged Waveguide Horn
ANTENNA 3 meter range;**

ITL # 1352, ETS 3115 s/n 29845

FREQUENCY	AFE	FREQUENCY	AFE
(GHz)	(dB/m)	(GHz)	(dB/m)
0.75	25.0	9.5	38.0
1.0	23.5	10.0	38.5
1.5	26.0	10.5	38.5
2.0	29.0	11.0	38.5
2.5	27.5	11.5	38.5
3.0	30.0	12.0	38.0
3.5	31.5	12.5	38.5
4.0	32.5	13.0	40.0
4.5	32.5	13.5	41.0
5.0	33.0	14.0	40.0
5.5	35.0	14.5	39.0
6.0	36.5	15.0	38.0
6.5	36.5	15.5	37.5
7.0	37.5	16.0	37.5
7.5	37.5	16.5	39.0
8.0	37.5	17.0	40.0
8.5	38.0	17.5	42.0
9.0	37.5	18.0	42.5



19. APPENDIX B - MEASUREMENT UNCERTAINTY

Occupied Channel Bandwidth	$7.7 \cdot 10^{-8}$ up to 2.9 GHz and $1.2 \cdot 10^{-7}$ from 2.9GHz to 12.75GHz.
RF output power, conducted	$\pm 25.53\%$ or $\pm 0.99\text{dB}$, Up to 2.9GHz and $\pm 26.91\%$ or $\pm 1.03\text{dB}$ from 2.9GHz to 12.75GH
Power Spectral Density, conducted	$\pm 25.53\%$ or $\pm 0.99\text{dB}$, Up to 2.9GHz and $\pm 26.91\%$ or $\pm 1.03\text{dB}$ from 2.9GHz to 12.75GH
Unwanted Emissions, conducted	$\pm 25.53\%$ or $\pm 0.99\text{dB}$, Up to 2.9GHz and $\pm 26.91\%$ or $\pm 1.03\text{dB}$ from 2.9GHz to 12.75GH
All emissions, radiated	$\pm 4.58\text{dB}$ Up to 2.9GHz, and $\pm 2.92\text{dB}$ from 2.9GHz to 12.75GHz